

## FLI8548H

### Single-Chip Enhanced LCD TV Controller with HDMI

#### APPLICATION

- LCD and PDP TV
- DLP™(1), LCD, and LCOS Front and Rear Projection

#### FEATURES

- Integrated HDMI input
- Integrated 3D Video Decoder
- Flexible Digital and Analog Capture up to 150 MHz
- VBI Signal Processing including WST version 2.5 support<sup>1</sup>
- Flexible DDR Memory Interface
- Faroudja® TrueLife™ Video Enhancer
- Advanced Picture-in-Picture (PiP) Features
- Advanced Color Management (ACM-3D) and Adaptive Contrast Control (ACC)
- On-Chip Microprocessor
- Advanced Bitmapped OSD Controller
- LCD Overdrive
- Embedded 10-bit Dual Channel LVDS for 1080p and WUXGA panel support

#### PACKAGE

- 416 PBGA

**FAROUDJA**  
DCDi CINEMA™

#### DESCRIPTION

The Genesis Microchip FLI8548H offers high integration for advanced applications of Picture-in-Picture (PiP) and Picture-by-Picture (PBP) with an integrated video decoder with a 3D comb filter, and an HDMI receiver. Additionally, the FLI8548H can power up to 1080p displays with the proven DCDi Cinema™-branded technology.

Special performance features such as the Faroudja® DCDi Cinema™ video format converter, 10-bit performance in the device, and the upgraded Advanced Color Management (ACM-3D) provide exceptional video quality. This exclusive level of video quality technology was previously only seen on Faroudja® Home Theater Systems but is now available in a single-chip solution.

The FLI8548H comprises an integrated Analog Front End (AFE) that includes triple ADCs and an integrated cross-point switch. The flexible AFE ensures simple PCB design with direct connections to TV tuners and input video connectors. In essence, the FLI8548H is the only device needed for a single LCD TV chassis supporting worldwide standards. For regional variations, only a connector and firmware change are required. The integrated VBI dataslicer and decoder remove the need for external components resulting in significant cost reduction. The FLI8548H supports many worldwide VBI standards for applications of Teletext, Closed Captioning, V-Chip, and other VBI services.

The FLI8548H can also be used as part of a digital TV solution that requires the proven Faroudja® DCDi Cinema™ video performance.

An embedded microprocessor and a versatile OSD in a single device will facilitate rapid development of a reliable and attractive product. The FLI8548H utilizes the common Cortez family firmware so migration is easy and effortless when moving across different hardware platforms within the Cortez family.

#### FLI8548H SYSTEM DIAGRAM

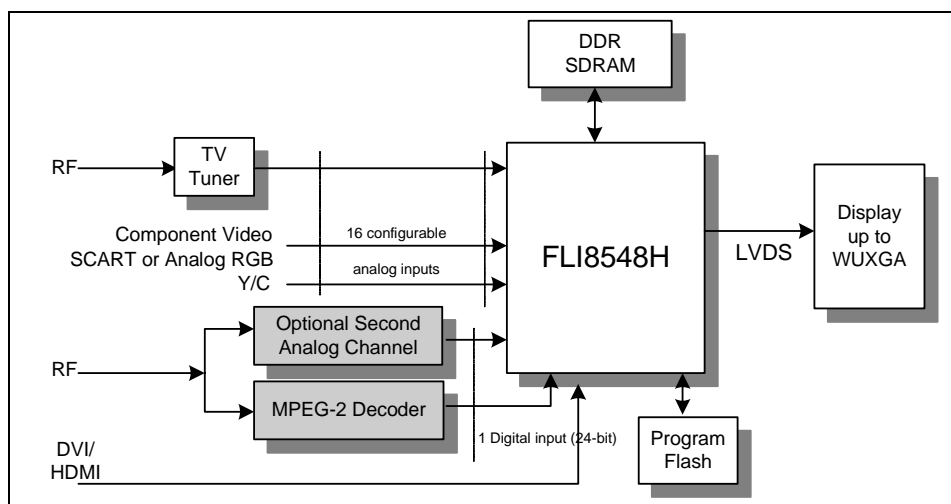

<sup>1</sup> Version 1.5 on-board support, version 2.5 with external memory

## FLI8548H FUNCTIONAL BLOCK DIAGRAM

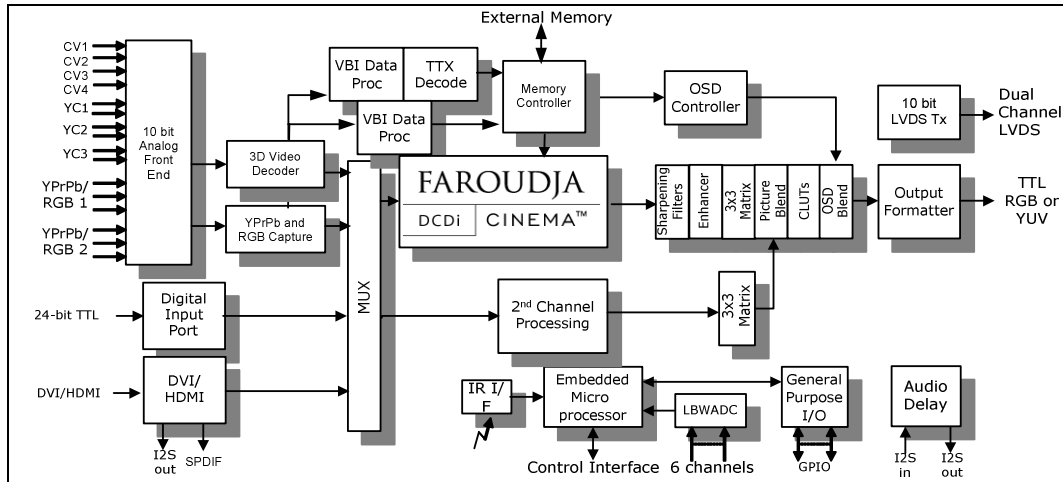

### FEATURE ATTRIBUTES

#### INTEGRATED 3D VIDEO DECODER

- Faroudja® IntelliComb™ Technology
- 3D Adaptive Comb Filter for Luma–Chroma separation
- Supports: Composite, S-Video, and Component (including High Definition) video input signals
- Support all broadcast TV Video standards—NTSC (North America and Japan), PAL (I, B, G, H, M, D, N), SECAM (D, K, L, B, G)
- Macrovision™<sup>(2)</sup> and VCR trick mode support

#### INTEGRATED 10-BIT ADC

- Supports triple 10-bit ADCs for better SNR

#### FLEXIBLE DIGITAL AND ANALOG CAPTURE

- HDMI input port with integrated PHY. Supports up to 1080p digital video input; passes audio out through I2S/SPDIF output.
- Integrated DVI 1.0 input supported<sup>(3)</sup>
- 16 configurable analog inputs
- Direct connection from tuner or connector to analog input pin
- Integrated Anti-Aliasing Filter
- RGB capture up to 135MHz
- YUV capture up to 150MHz
- Full SCART support including RGB Fast Blank
- 4:4:4:2:2/CCIR656/601 8/16/24 bit digital input port
- Simple connection to JPEG and MPEG processors with a 8-bit bi-directional Media Port

#### FAROUJIA DCDi CINEMA™ FORMAT CONVERSION

- Low Angle De-interlacing processing
- Per Pixel Motion Adaptive De-interlacing (MADi) up to 1080i format
- Format conversion up to WUXGA resolutions
- Panoramic and Anamorphic non-linear scaling
- Adaptive Media Display Processing for 3:2 and 2:2 video content
- Adaptive 3D Noise Reduction
- Media Noise Reduction for MPEG inputs
- Supports 2.2 Film Mode processing

#### VBI SIGNAL PROCESSING

- Multi-standard Digital VBI datascraper
- WST Teletext FastText page support access with above 2048 page cache
- Support for WST level 2.5
- V-chip, VPS, Closed Captioning, XDS, CGMS, and WSS decode
- Supports VBI frame freeze

#### FLEXIBLE X16 OR X32 DDR MEMORY INTERFACE

- DDR1 440MHz memory supported in configurations of 1x16, 2x16, 1x32
- Memory size is flexible up to 512Mbits

#### LCD OVERDRIVE

- Reduces video smearing artifacts of rapid luminance transition scenes caused by slow LCD panel response

#### ADVANCED BITMAPMED OSD CONTROLLER

- 16 True Color bitmap tiles with 1, 2, 4 and 8-bit per pixel
- Horizontal and vertical stretch of OSD menus
- Blinking, transparency, and blending
- Supports Character Font scaling

#### FAROUJIA® TRUELIFE™ VIDEO ENHANCER

- High performance and programmable sharpening filters with noise coring
- Non-linear Chroma enhancement
- Non-linear Luma enhancement
- Removal of the DVD Chroma Upsampling Error (CUE) introduced by some DVD sources

#### PICTURE-IN-PICTURE (PIP)

- Dynamic Scaling for advanced PiP transitions
- Video PiP over full screen graphics background
- Graphics PiP over full screen video background
- Video PiP over full screen video background
- Side-by-side window support
- PiP Zoom Support
- Multi-PIP

#### ADVANCED COLOR MANAGEMENT (ACM-3D)

- Advanced 3D Active Color Management (ACM-3D) provides flexible programming, polar coordinate representation, and six-axis color control
- ACM-3D allows flexible flesh-tone compensation, blue stretch, and other image enhancements
- Adaptive Contrast and Color (ACC) ensures full dynamic range is used in video content

#### ON-CHIP MICROPROCESSOR

- Integrated x186 based microprocessor with rich function library
- General-purpose inputs/outputs (GPIOs) available for managing system devices (keypad, backlight, NVRAM, etc)
- Advanced power control for low power stand-by mode
- 2-wire serial master bus interface for external device control

#### OUTPUT FORMATS

- Dual-channel TTL output
- Dual-channel LVDS transmitters for direct connection to LCD modules
- 30-bit LVDS and TTL output available; 24-bit 4:2:2 YUV TTL output—12 bits per color
- 1080p and WUXGA panel support

#### OTHER FEATURES

- Integrated infrared decoder and low bandwidth ADC with 6 channels of input
- 4 integrated PWM outputs (e.g. LCD backlight control)
- Integrated I2S Audio Delay for exact Audio and Video Synchronization
- I2S channel MUX to support two I2S input streams
- Programmable horizontal filter coefficients

<sup>1</sup> DLP is a trademark of Texas Instruments Incorporated

<sup>2</sup> Macrovision is a trademark of Macrovision Corporation

<sup>3</sup> DVI and HDMI are mutually exclusive